

M12x1.75 THREAD x 1.00 DEEP
 C'BORE DIA .492 x .236 DEEP

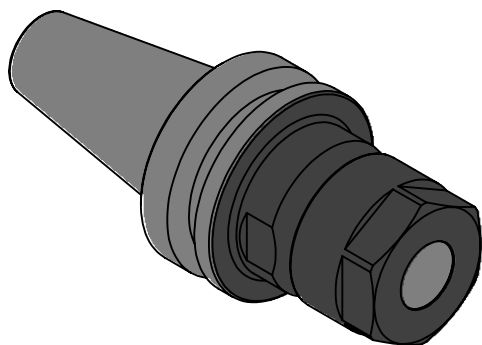
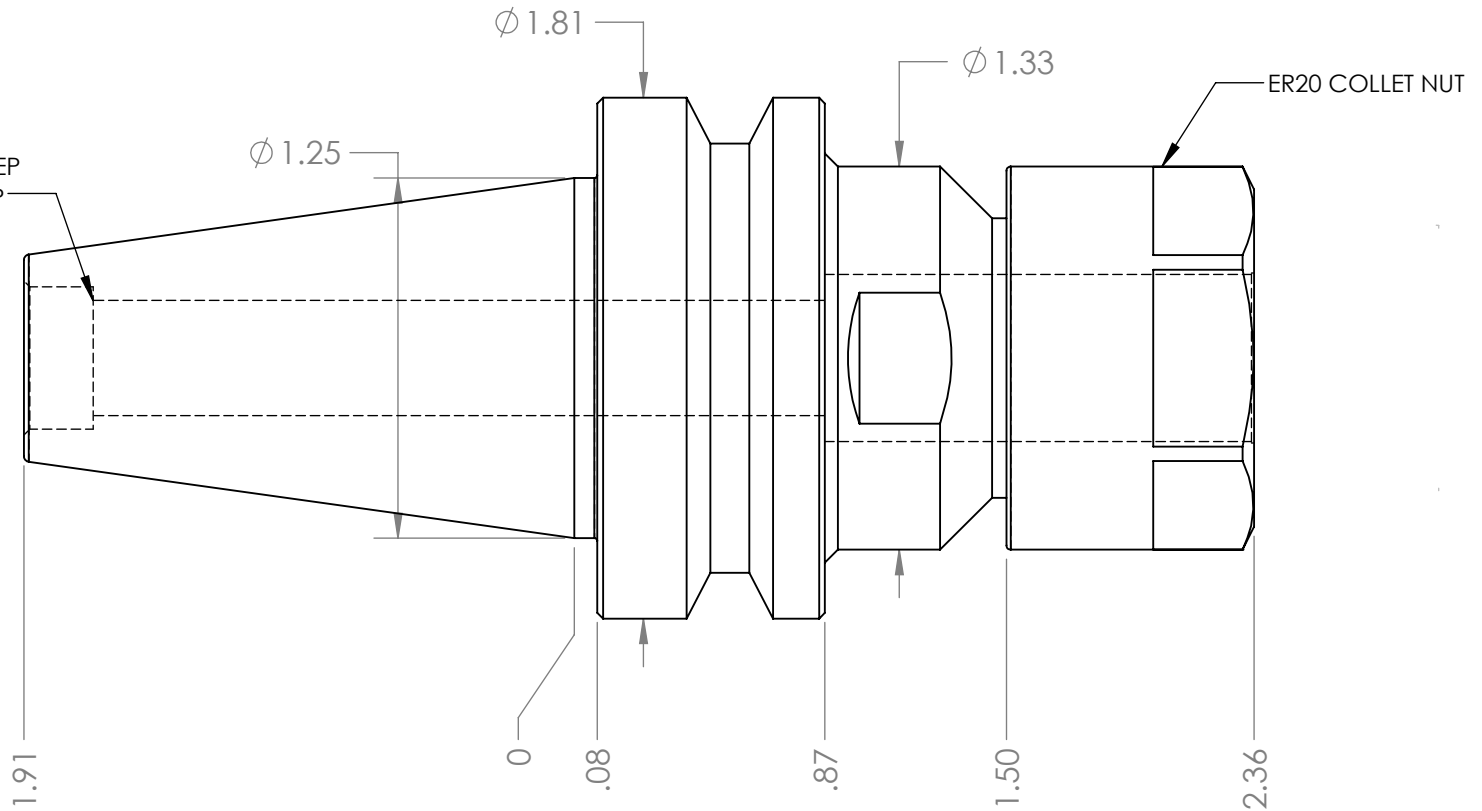

NOTES:
 WORKS ON ALL BT30 MACHINES
 TAKES ALL ER20 COLLETS FROM .039"-.5625"
 USES WRENCH PART # ER20-WRENCH (NOT INCLUDED)
 FOR MORE PRODUCT DETAILS PLEASE GO TO MARITOO.COM
 AND SEARCH ITEM # LISTED ON THIS PRINT

MARITOO

WWW.MARITOO.COM

ITEM# **BT30 ER20-60W**

Made in USA